

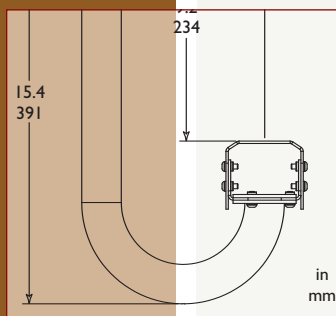

- Wall & Ceiling Versions
- Sturdy Construction
- 360° Rotation, 180° Tilt
- Feed-through models available
- Adjustable Mount Heads
- Lightweight
- Corrosion-resistant Finish

## Housing Mounts

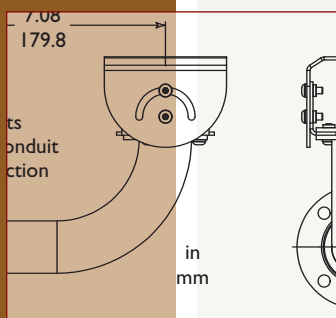
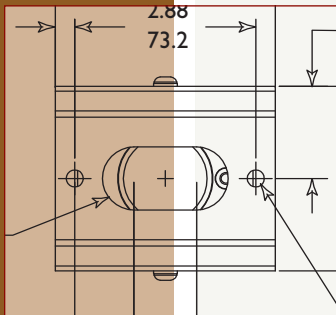

### MT9210, MT9212, MT9223 MT9215, MT9215S, MT9217, MT9219

Aigis offers a variety of mounting options for housing installations with up to a 20 lb (9 kg) rated load. These models are made of lightweight aluminum and feature welded construction, providing an extremely rigid camera mount. In addition, the versatile swivel head rotates 360° and tilts 180° for maximum flexibility.

The feed-through versions have a center opening to allow wiring to pass inside the mount shaft hidden from view. Using these products to mount a housing specifically designed for bottom feed-through wiring, such as the HS948x series, creates a clean, wire-free look.

# SPECIFICATIONS

## INDOOR/OUTDOOR HOUSING MOUNTS

MODEL	DESCRIPTION	SIZE	MOUNTING HEAD	MAXIMUM LOAD	WEIGHT	FOR USE WITH
<b>STANDARD MODELS* (NON FEED-THROUGH)</b>						
MT9210	column mount	8-inch (200-mm)	Adjustable 360°pan, 180° tilt	20 lb (9 kg)	0.6 lb (0.3 kg)	medium size housing assembly
MT9223	column mount	24-inch (610-mm)	Adjustable 360°pan, 180° tilt	20 lb (9 kg)	1.2 lb (0.55 kg)	medium size housing assembly
MT9212	wall mount	12-inch (307-mm)	Adjustable 360°pan, 180° tilt	20 lb (9 kg)	0.9 lb (0.4 kg)	medium size housing assembly
<b>FEED-THROUGH MODELS**</b>						
MT9215	wall mount	12-inch (307-mm)	Adjustable 360°pan, 180° tilt	20 lb (9 kg)	0.9 lb (0.4 kg)	medium size housing assembly
MT9215S	wall mount	7-inch (180-mm)	Adjustable 360°pan, 180° tilt	20 lb (9 kg)	0.9 lb (0.4 kg)	small housings (HS9480)
MT9217	column mount	8-inch (200-mm)	Adjustable 360°pan, 180° tilt	20 lb (9 kg)	0.6 lb (0.3 kg)	medium size housing assembly
MT9219	ceiling j-mount	12-inch (307-mm)	Adjustable 360°pan, 180° tilt	20 lb (9 kg)	1.2 lb (0.55 kg)	medium size housing assembly

\* These models work best with the HS938x series housings and are not designed for feed-through wiring.

\*\* These models work best with the HS948x series housings that are specifically designed for feed-through wiring, and **are not compatible** with the HS938x series.

All items offered in a light gray finish. Contact Aigis if custom colors are required.

**Accessory for MT9212, MT9215 and MT9215S: MT9213 Pole Mount Adapter (see drawing).**

### Housing Mounts - MT9210, MT9223, MT9212

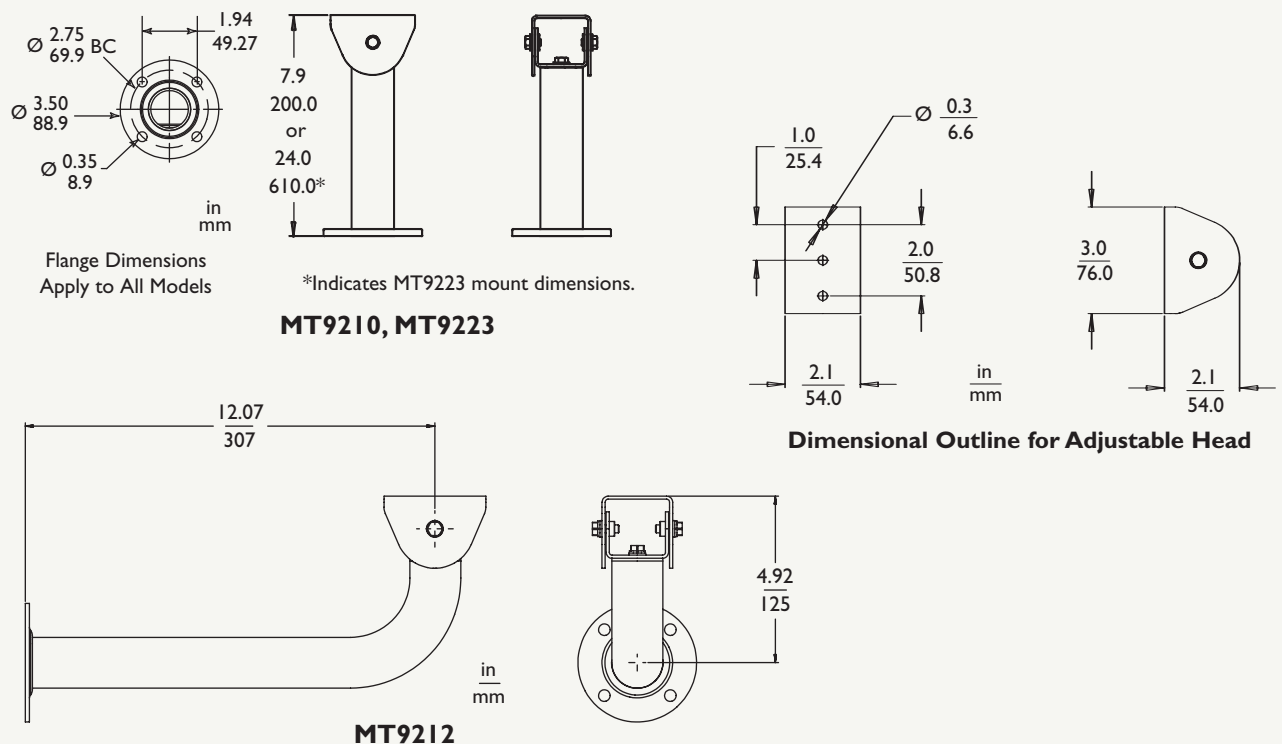

### MT9215, MT9217 Feed-through Mounts

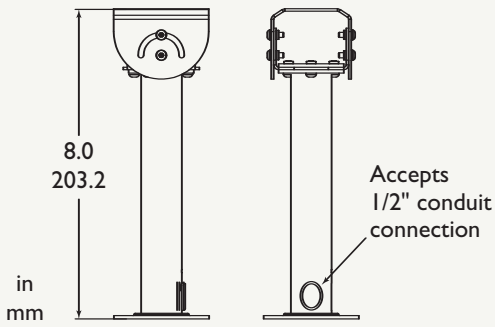

**MT9217 Column Mount**

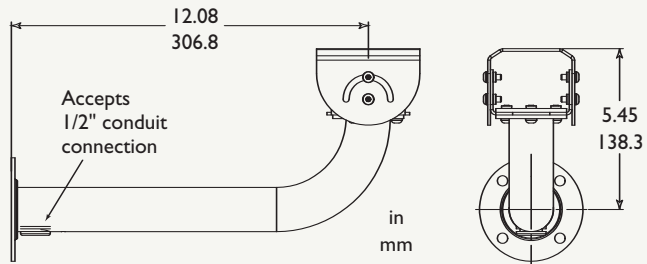
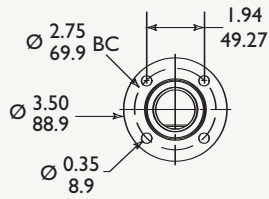
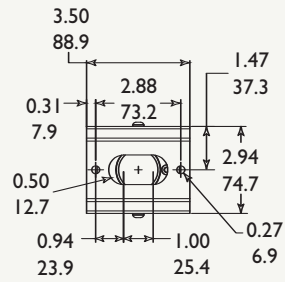

**MT9215 Wall Mount**

### MT9215S Feed-through Wall Mount

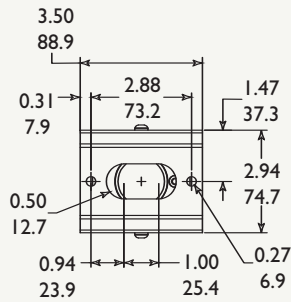
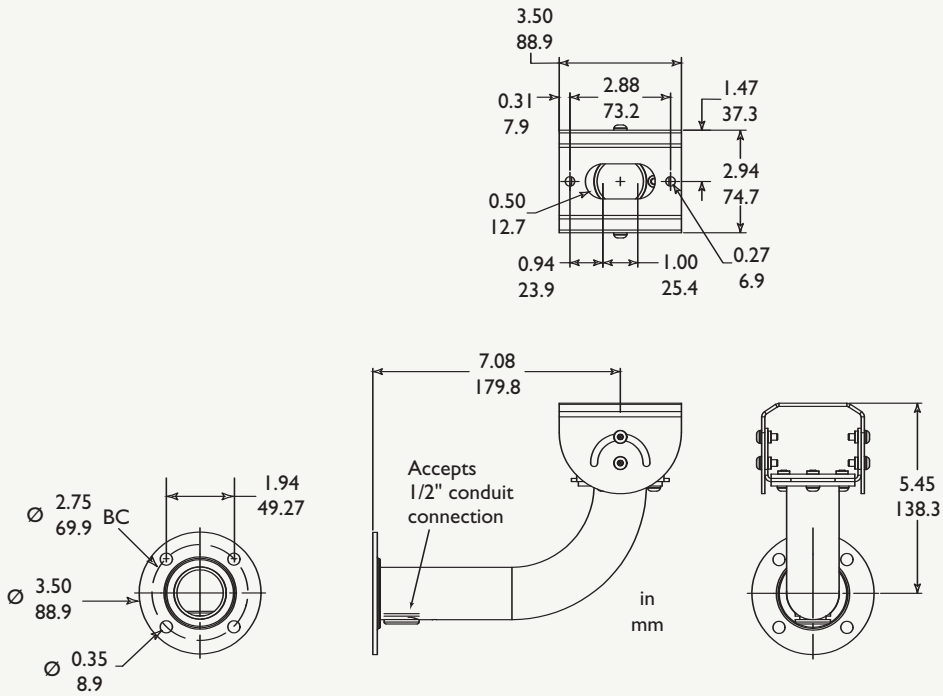

### MT9219 Feed-through Ceiling J-mount

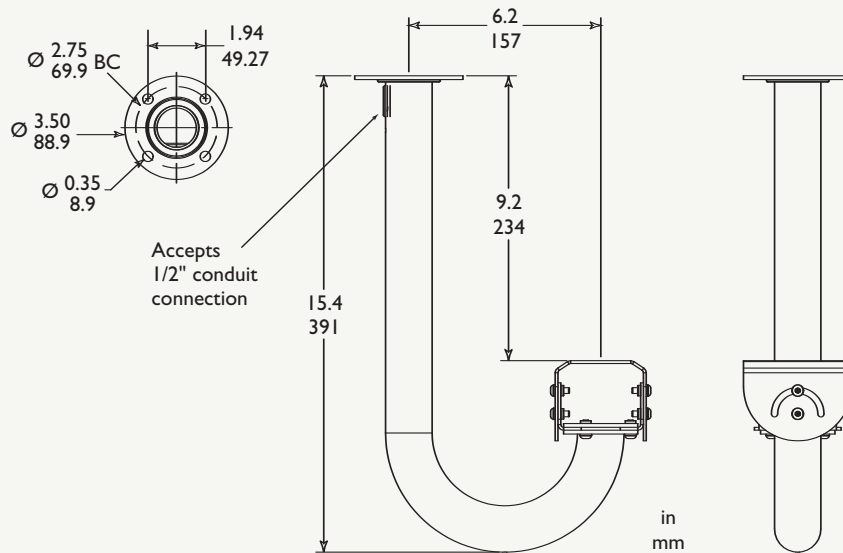

**WARNING: Mounts must be mounted as shown.**

### MT9213 Pole Mount Adapter

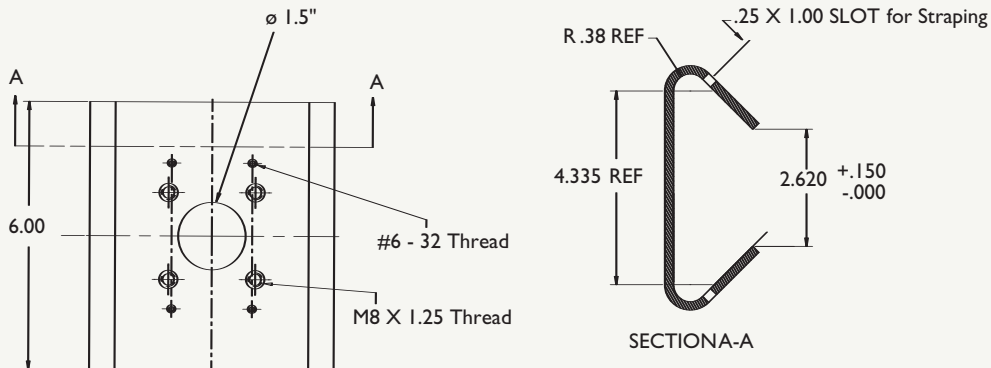

**Mounting Hardware:** (2) 5 ft (1.5 m) stainless steel straps, (2) banding clips, (4) hex head cap screws, and (4) lockwashers are furnished with unit.

**Approx. Weight:** 1.9 lb (850 g).

**Options:** PM3T strapping tool.

Requires mounting pole of 3 inch to 15 inch (76 mm to 381 mm) OD.

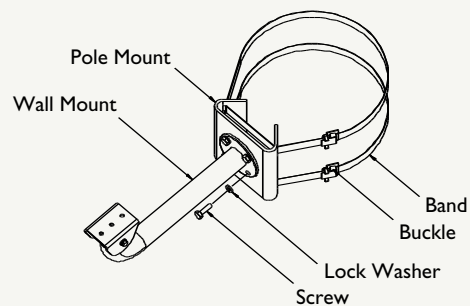

**MT9213 Pole Mount Adapter and Stainless Steel Straps**



mechtronics

©2003 Aigis Mechtronics

1124 Louise Road, Winston-Salem, NC 27107-5450

Tel: 336.785.7740 Fax: 336.785.7744

www.aigismech.com

Data subject to change without notice