

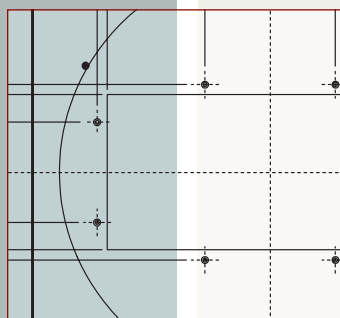

- For Fixed or Suspended Ceilings
- Convenient Key Lock Access
- Easy Installation
- Attractive Low Profile Styling
- Suitable for Use in Environmental Air Spaces
- Rotatable Ceiling Tile Mounting Kits Available

## Ceiling Housings

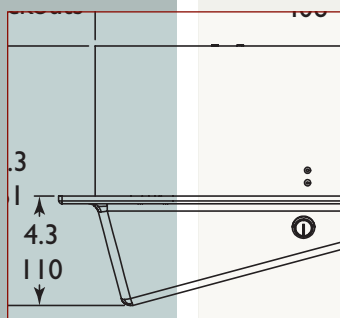
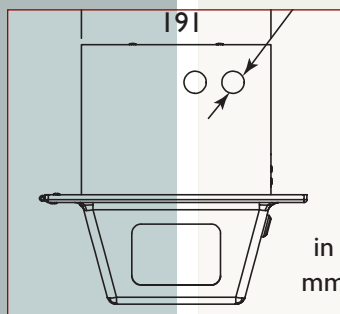

### HS9369, HS9370

The HS9369 and HS9370 models are aesthetically designed, small, low profile indoor ceiling housings for CCTV camera installations. These housings can be easily mounted in fixed or suspended ceilings and are ideal for any application where attractive and discrete CCTV monitoring is required.

Their construction consists of a tough acrylic/PVC alloy plastic cover hinged to an aluminized steel backbox. This construction allows these housings to be used in environmental air spaces or in air handling plenum of a nonfire-resistant ceiling. Other construction features include key lock access, a polycarbonate window, an adjustable camera mount system, and cable entry through conduit knockouts.

Mounting kits are available for 2 ft x 2 ft and 600 mm x 600 mm suspended ceiling tiles. These mounting kits allow 360° rotation and easy installation.

# SPECIFICATIONS

## MECHANICAL

Model	Maximum Camera/Lens Size	Weight	Mounting Kits*
HS9369	13 L x 4 W x 4 H in (330 L x 102 W x 102 H mm)	7.5 lb (3.4 kg)	HS9069 HS9069M
HS9370	8.2 L x 2.75 W x 2.5 H in (208.3 L x 69.8 W x 63.5 H mm)	5.3 lb (2.4 kg)	HS9070 HS9070M

\* Optional mounting kits are available as accessory items.

**Cable Entry:** Wiring access available through four (two front and two back) PG13.5 (1/2 in) conduit knockouts.

**Window:** 0.13 in (3.2 mm) thick polycarbonate.

**Housing Mounting:** Eight protected 0.27 in (7 mm) holes in backbox. Top of backbox contains two 0.25 in (6 mm) knockouts for safety cable wiring.

**Camera Mounting:** Two piece adjustable mounting system.

**Construction/Finish:**

Cover: 0.06 in (1.6 mm) acrylic/PVC alloy plastic with a haircell texture and light gray color.

Backbox: 0.04 in (1 mm) aluminized steel.

**Dimensions:** See **Dimensional Outline**.

## ENVIRONMENTAL

**Enclosure Protection:** Cover and window meet UL Flame Rating 94V-0.

## ACCESSORIES

### MOUNTING KITS:

Ceiling tile mounting kits for suspended ceiling installations. Constructed of 0.04 in (1 mm) aluminized steel painted with dark mushroom powder coat. Rotates through 360°. (See Drawings)

**HS9069:** Replaces a 2 ft x 2 ft ceiling tile.

**HS9069M:** Replaces a 600 mm x 600 mm ceiling tile.

**HS9070:** Replaces a 2 ft x 2 ft ceiling tile.

**HS9070M:** Replaces a 600 mm x 600 mm ceiling tile.

### HS9369 - DIMENSIONAL DRAWING

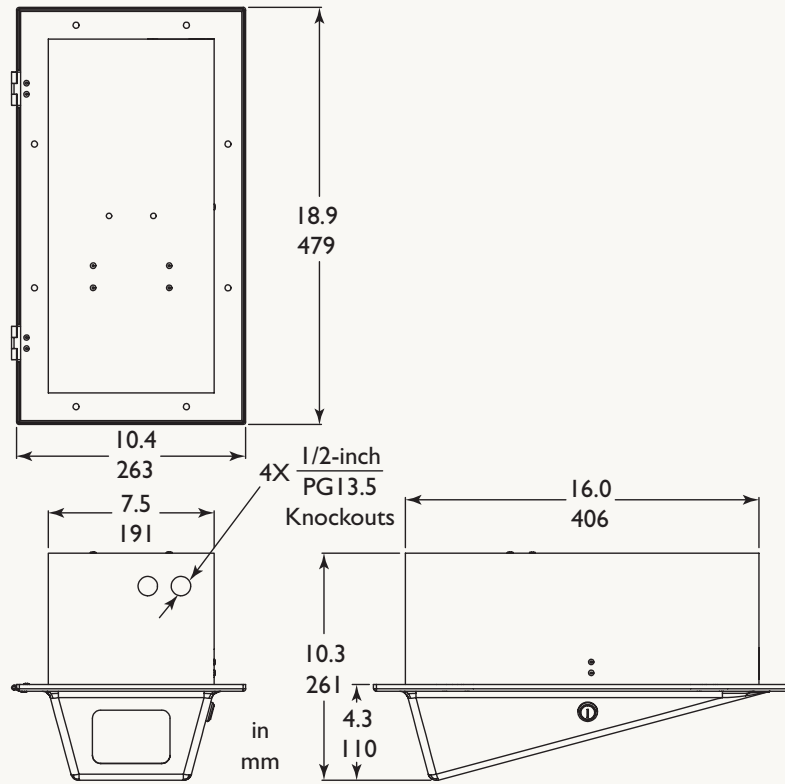

### HS9370 - DIMENSIONAL DRAWING

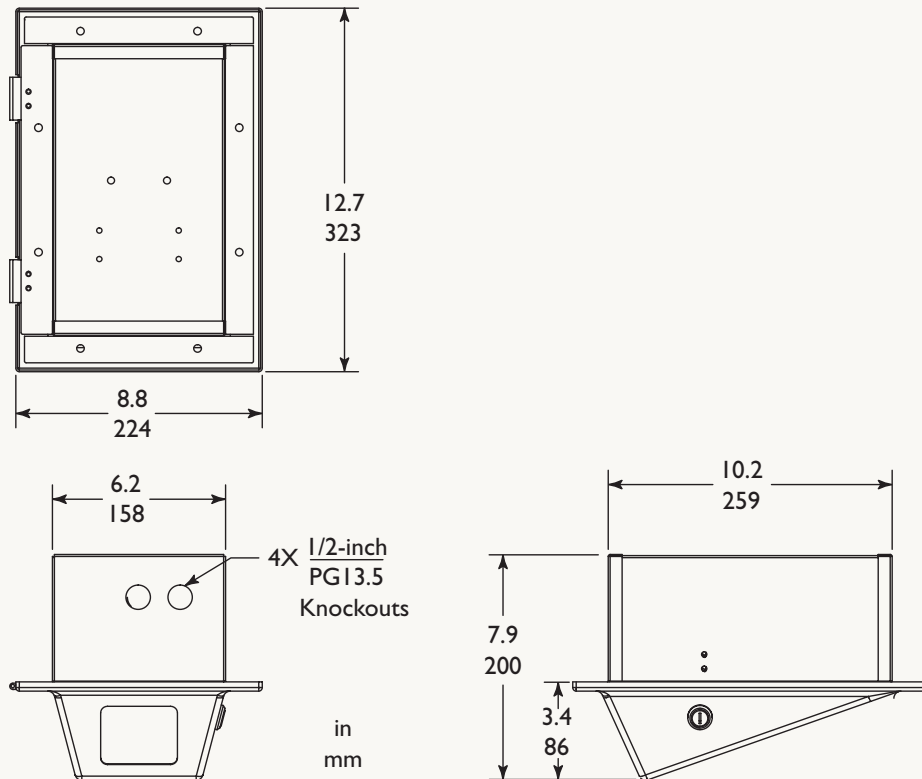

### HS9069, HS9069M - MOUNTING KITS

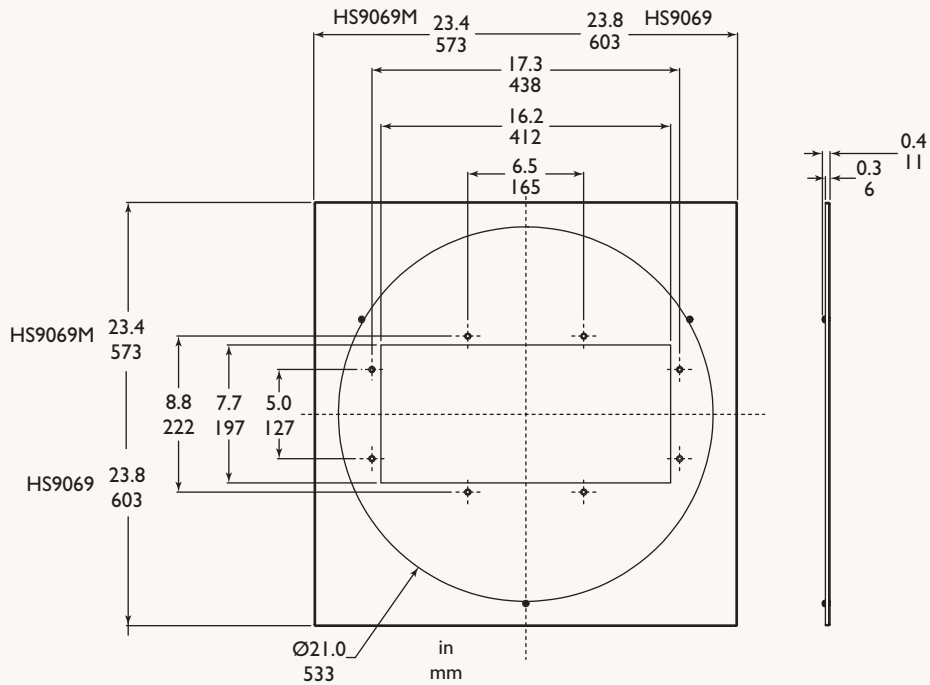

### HS9070, HS9070M - MOUNTING KITS

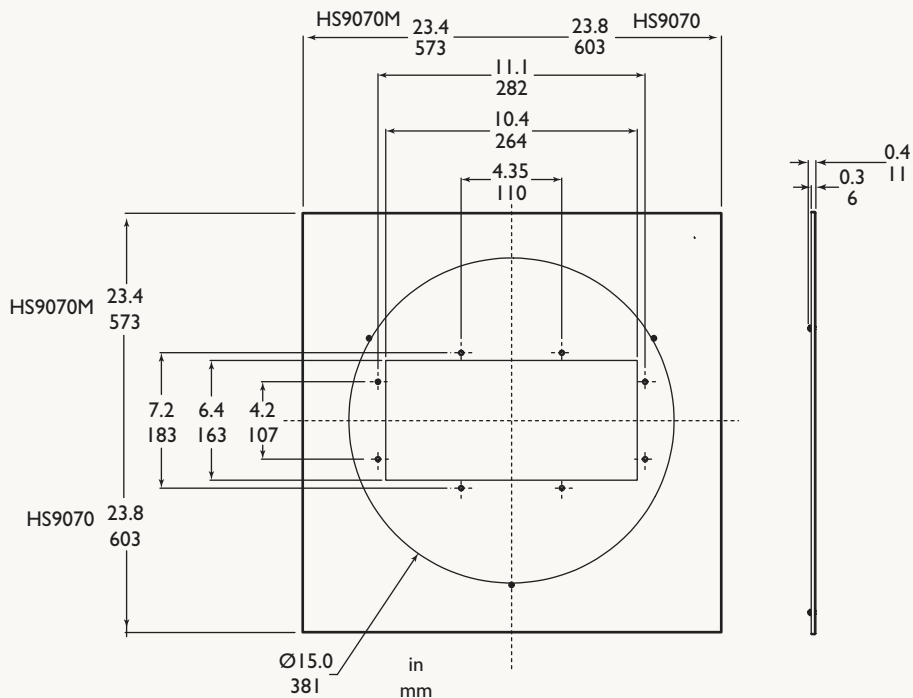

mechtronics

©2003 Aigis Mechtronics

1124 Louise Road, Winston-Salem, NC 27107-5450

Tel: 336.785.7740 Fax: 336.785.7744

www.aigismech.com

Data subject to change without notice