

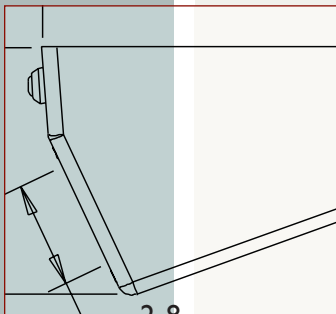

- Rugged Cast Aluminum Construction - Equivalent to 10 Gauge Steel
- Easy Installation
- Scratch-resistant Polycarbonate Window
- Adjustable Camera Mounting System
- Compact Design
- Accessories Available

Wall/Ceiling Security Housings

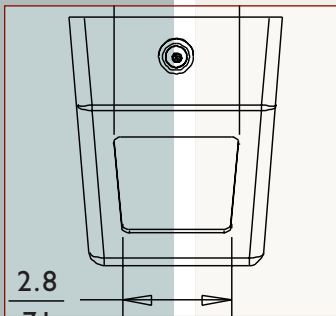
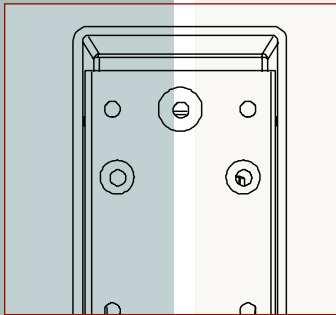

HS9305, HS9405 Series

The HS9305 and HS9405 Series models are wall or ceiling mounted detention grade security housings designed for applications such as prisons, parking garages, and hospitals. Attractively styled, these housings can be mounted on a ceiling or on a wall horizontally or vertically.

For maximum protection and durability, the lightweight cast aluminum design of these housings provides the strength of 10 gauge steel with the superior strength-to-weight ratio of aluminum. The viewing window is constructed of 0.37 inch (9.5 mm) clear polycarbonate material, treated with a scratch-resistant coating. A removable, hinged cover provides easy access to the camera and is secured by a tamper-resistant screw.

If additional security is required, models are available with a key lock in the access panel, a tinted 0.37 inch (9.5 mm) viewing window, and a 0.5 inch (12.7 mm) clear viewing window. Defogger kits are available for the HS9305 Series.

ORDERING GUIDE

Order the security housing that meets your needs. Start with the model that fits your camera specifications. Add options alphabetically in a variety of combinations. The standard model has a clear 0.37 inch (9.5 mm) thick polycarbonate window. By selecting from the options below, you can choose to tint the window (T), make it thicker (W) - or both (TW). You can also select key lock access (L). Accessories are available.

EXAMPLE: HS9305LW

MODEL	option	option	option
	L	T	W
HS9305 HS9405 Security Housings	L - Key lock controlled access	T - Tinted 0.37inch (9mm) viewing window	W - Clear 0.50 inch (12.7mm) viewing window

• Always add option(s) alphabetically: -L, -T, -W, -LT, -LW, -TW, -LTW •

SPECIFICATIONS

Housing	Construction	Cast aluminum cover mounted to a high strength steel top panel and assembled using high strength steel hardware. Cover is secured with a captive security screw. Cover Thickness - HS9305: 0.25 in (6.3 mm); HS9405: 0.23 in (5.8 mm)
	Finish	Light Gray
	Window	0.37 in (9.5 mm) thick polycarbonate treated with a scratch-resistant coating. Standard models clear. Tinted and thicker options available. (listed above) Design allows for easy replacement.
	Weight	HS9305: 12.3 lb (5.6 kg); HS9405: 5.8 lb (2.6 kg)
Cable Entry		Wiring access through one PG 21 (3/4 in) and two PG 13.5 (1/2 in) conduit knockouts located in the top of the housing. Open cable entry is also available through the top.
Mounting	Surface Mount	Protected top panel contains six 0.4in (10mm) holes for easy installation.
	Camera Mounting	Removable three piece fully adjustable mounting system.
Maximum Camera/Lens	HS9305	Accepts camera/lens combinations up to 11.8 x 3.0 x 3.0 in (300 L x 76 W x 76 Hmm) when using 1/4-inch, 1/3-inch and 1/2-inch format CCD cameras. Dimensions include standard connectors.
	HS9405	Accepts camera/lens combinations up to 7.5 x 2.7 x 2.7 in (190 L x 68 W x 68 Hmm). Dimensions include standard connectors. A right angle BNC may be required for some cameras.

ACCESSORIES

	Recommended for use in areas where condensation could cause fogging of the viewing window.	
Defogger Kits for HS9305	HS9315-6	115 VAC, 50/60 Hz, 50 W thermostatically-controlled defogger kit
	HS9315-2	24 VAC, 50/60 Hz, 50 W thermostatically-controlled defogger kit
	HS9315-5	230 VAC, 50/60 Hz, 50 W thermostatically-controlled defogger kit

HS9305 SERIES DIMENSIONAL DRAWING

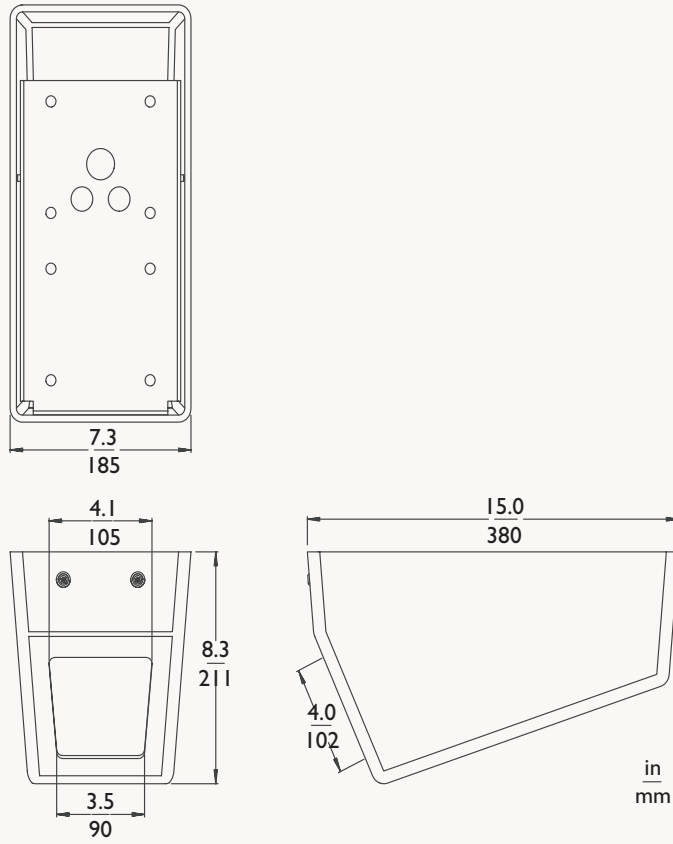

HS9405 SERIES DIMENSIONAL DRAWING

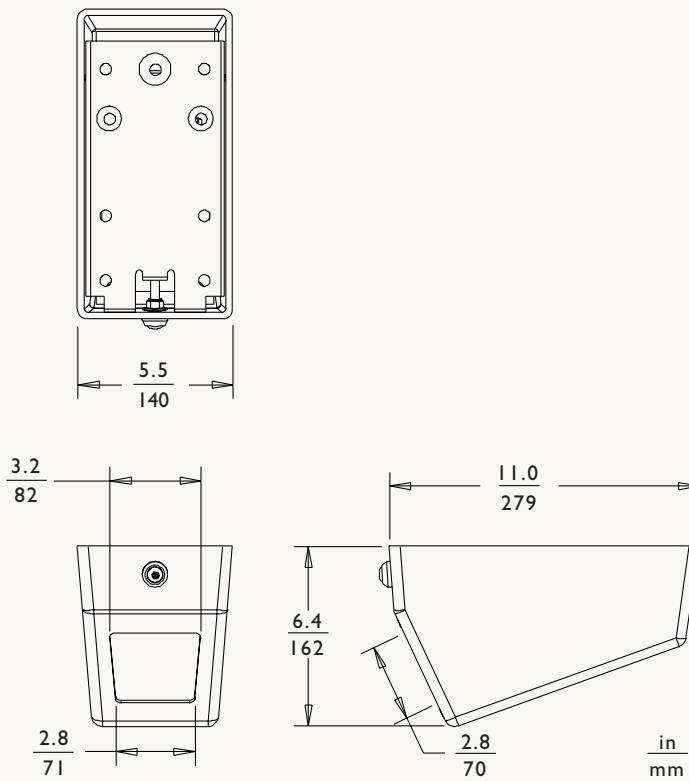



mechtronics

©2003 Aigis Mechtronics

1124 Louise Road, Winston-Salem, NC 27107-5450

Tel: 336.785.7740 Fax: 336.785.7744

www.aigismech.com

Data subject to change without notice

04/04 rev_01
Printed in U.S.A.