

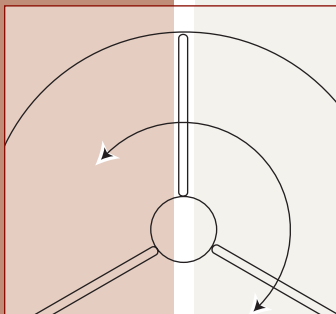

- **Lightweight Removable Control Mechanism**
- **Field Changeable for Fail Safe or Fail Secure Operation**
- **Outdoor Rated & Easy to Assemble**
- **Linear Action Centering**
- **Shock Absorption at all Impact Points**
- **Slide Door Service Access**
- **Large Block Terminals for Field Connections**
- **1-1/8" thick Hard Coated Ratchets with 1" thick Hard Coated Pawls**

Full Height Aluminum Turnstile Series

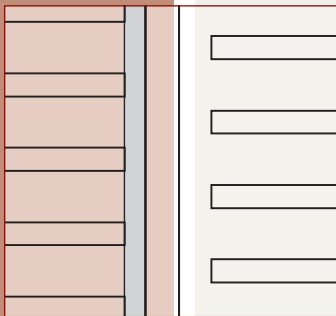
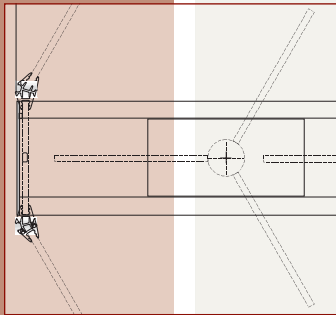

AT-FAL Series

The AT-FAL full height aluminum turnstile series provides superior access control through solid construction and safe design. These units are rated for outdoor use and are available in clear and bronze anodized finishes.

This unit was developed with the installer in mind and can be assembled in a fraction of the time it takes to install comparable industry models. Alignment pins and other self-aligning features make the assembly process simple and reduce potential mistakes. Should requirements change after installation, a user can easily change these units (that come electrically pre-configured) from fail-safe to fail-secure.

To prevent shock and vibration from transferring through the turnstile frame, all areas where mechanical impact occurs during normal operation (ratchets, pawls, spindle connection points and mechanism mounts) are insulated with shock absorbing materials. This unique design assures a quiet and smooth operation of the turnstile and adds to the life of all mechanical parts.

Aigis does not charge extra for safety! Included with every turnstile are the following safety features: Heel protection, Red and Green LED indicator lights, Home Position centering of spindle and Relocking timer.

ORDERING GUIDE

Order the turnstile that meets your needs. Start with the product category, then specify the finish, configurations and options you need to complete your custom turnstile. If you need further customization - call the factory with your exact specification requirements.

EXAMPLE 1: (SINGLE UNIT) AT-FALCS21 = A clear anodized, single passageway turnstile with fail-secure entrance and fail safe exit in the controlled direction(s).

EXAMPLE 2: (DOUBLE UNIT) AT-FALCD2121 = A clear anodized, double passageway turnstile with fail-secure entrances and fail safe exits in the controlled direction(s).

AT	type	finish	configure	Single Units		Double Units	
				entrance 1	exit 1	entrance 2	exit 2
	FAL	C	S	2	1	2	1
Aigis Turnstile	F - Full Height Aluminum	C - Clear Anodize B - Bronze Anodize	S - Single D - Double	1 - Fail-Safe	1 - Fail-Safe	1 - Fail-Safe	1 - Fail-Safe
				2 - Fail-Secure	2 - Fail-Secure	2 - Fail-Secure	2 - Fail-Secure
				3 - Not Used	3 - Not Used	3 - Not Used	3 - Not Used
				4 - Manual	4 - Manual	4 - Manual	4 - Manual

TURNSTILE SPECIFICATIONS	
OPTION	
Primary Voltage	115V
Power	40W
Solenoids	24VDC. 14W
Control Boards	20VAC Input, 5A Contacts Independent Controller for each Direction of Turnstile Rotation Fail-safe / Fail Secure Switch Processor Control Logic Accept Momentary (1sec or less) Dry Contact Closure to Activate Timed Auto Re-Lock Turnstile When Not In Use
Passageway	28"w X 80"h Clear Passage Anodized Aluminum Frame with Clear Polycarbonate Scratch Resistant Panels Auto Alignment Extrusions for Positive Installation Location No Gaps Between Panels
Spindle Section	Full Height Center Column with Positive Alignment for Arm Sections Decorative Filler Extrusions between Spindle Arm Sections
Spindle Arm Sections	9 Arms Pre-assembled and Locked into Vertical Retainer Auto Position and Locking Locator Pin Holes, Top and Bottom
Barrier Section	9 Arms Pre-assembled and Locked into Vertical Retainer
Ceiling Plates	1/8" Anodized Aluminum Plates Prevent Crawl Over
Header and Cover	Provided in Sections for Easy "One Person Assembly" Light Weight Sliding Lockable Access Panels Access for Removal of Control Mechanism
Controller Mechanism	8" O.D. x 1-1/8"t Ratchets 1-1/2"w X 1"t Pawls Shock Absorbing Bushings in Ratchets and Pawls Shock Absorbing Mounting for Mechanism Linear Acting Self Centering Hydraulic Energy Absorber at end of each Cycle Self Aligning Solenoids Quick Change Configuration (fail-safe, fail-secure)
Standard Safety Features	Red/Green LED Indicator Lights for Each Direction of Control Padded Heel Protection Home Position Centering of Spindle Arms

Easy access to the operating mechanism, control board(s) and other components located in the header area is accomplished through sliding panel doors that are key lockable. All bearings are permanently lubricated requiring no scheduled maintenance. The lower spindle bearing is located inside the spindle column and will not be exposed to salt, sweep cleaners or other floor maintenance materials that could cause failure. All shafts and hardware are made from stainless steel.

DEFINITIONS:

- 1. Fail-Safe:** Upon loss of electrical power the turnstile center spindle will rotate freely in the entrance or exit direction that is selected with this option from the ORDERING GUIDE.
- 2. Fail-Secure:** Upon loss of electrical power the turnstile center spindle will remain locked in the entrance or exit direction that is selected with this option from the ORDERING GUIDE.
- 3. Locked:** The center spindle will always be locked in the entrance or exit direction that is selected with this option from the ORDERING GUIDE.
- 4. Manual:** The center spindle will always freely rotate in the entrance or exit direction that is selected with this option from the ORDERING GUIDE.

CAUTION:

For safety reasons do not combine electrically controlled and manually controlled on the same center spindle.

AT-FAL SERIES (SINGLE) - DIMENSIONAL DRAWINGS

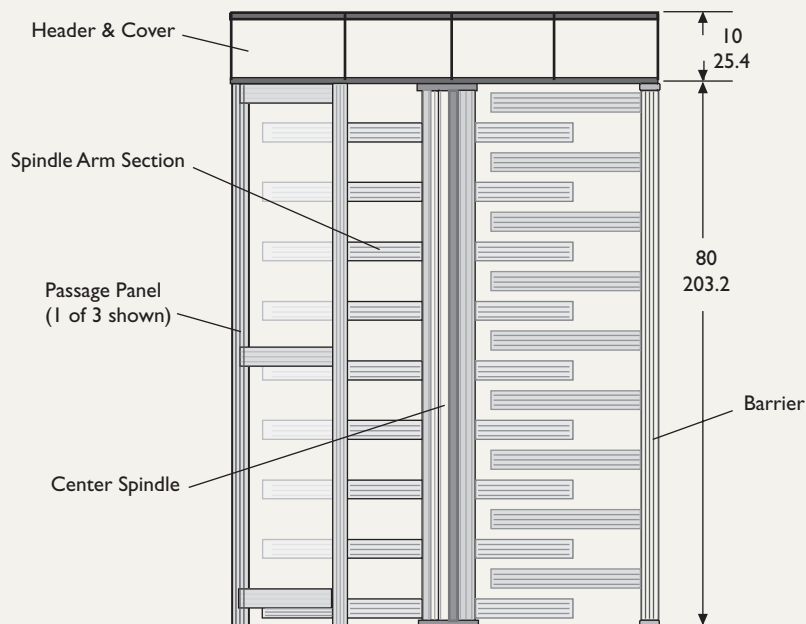
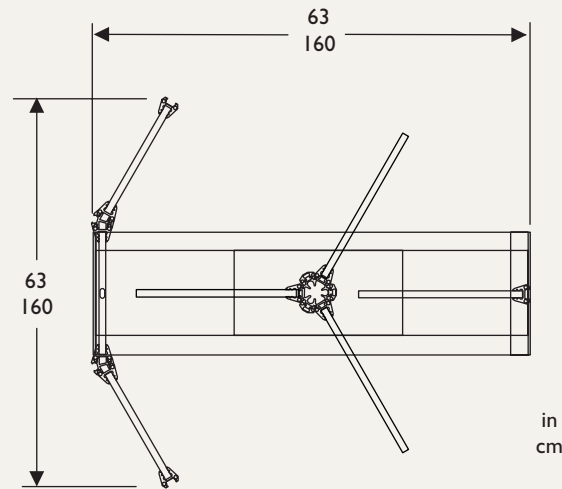

AT-FAL SERIES (DOUBLE) - DIMENSIONAL DRAWING

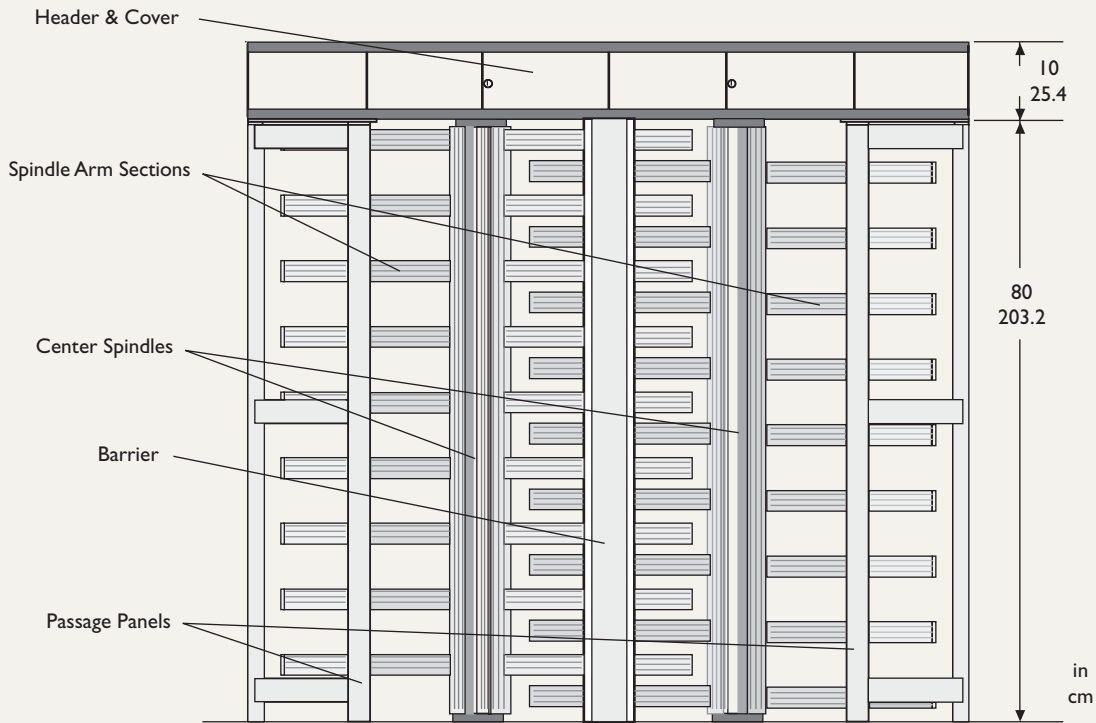
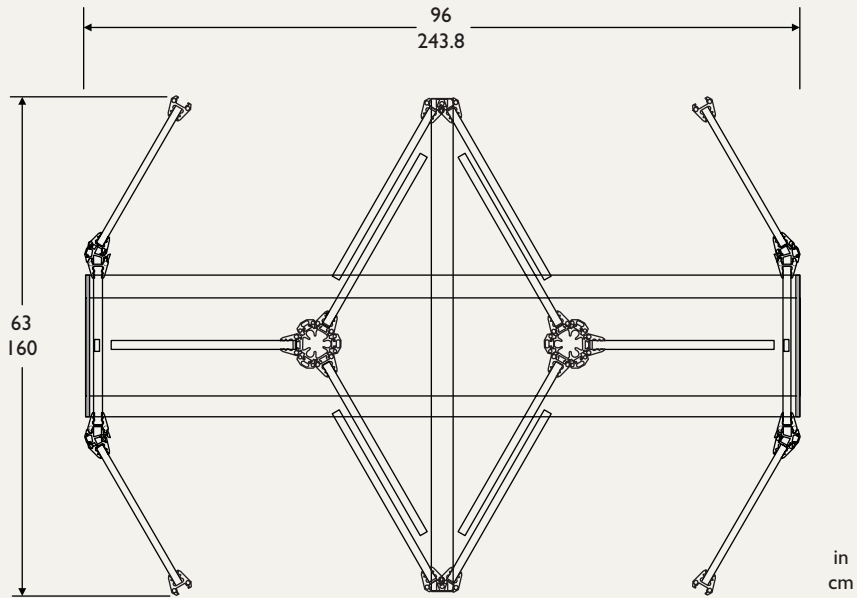

mechtronics

©2004 Aigis Mechtronics

1124 Louise Road, Winston-Salem, NC 27107-5450

US: 877.523.6500 Tel: 336.785.7740 Fax: 336.785.7744

www.aigismech.com

Data subject to change without notice